

BANNER BAR SYSTEM ASSEMBLY AND USER GUIDE

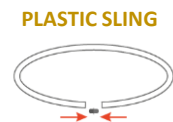

1. Push the **sleeve** onto the top of the flagpole.
2. Attach the sleeve to the flagpole with **two screws**.
3. Using a plastic sleeve, cover the top of the sleeve with the **cap**.
4. Press the clip on the **crossbar** and slide the tip of the crossbar into the sleeve's crossbar holder arm in a way that the **clip** would lock into the small **hole** in the holder.
5. Insert the **plastic fix-lock** through the opening in the sleeve.
6. Place the **ring weight's collar** around the flagpole and close it with the **counterweight**; attach the **metal snap hook** to the counterweight.
7. Push the **crossbar** all the way through the pole pocket in the banner.
8. Attach the **upper loop** of the banner to the plastic fix-lock (*installed in point 5*).
9. Attach the **lower loop** of the banner to the metal snap hook, which is attached to the counterweight.
10. Wrap the **slings** around the pole and through the loops in the mid-part of the banner's edge. Close the slings' ends.
11. Screw the **finial** onto the sleeve.
12. Push the **flagpole** upright and level it with the adjusting nuts; tighten the nuts.
13. Check and, if necessary, tighten the nuts 2 - 3 weeks after installing the pole. Also check the nuts when changing the banner (every 3 to 6 months).

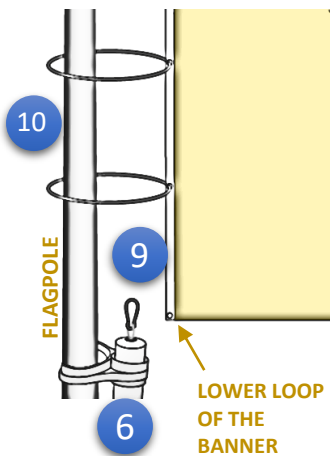

Flagmore[®]

www.flagmore.com